

BI-LEVEL MOTION SENSOR SUPPLEMENT
MSITXLOD500SPASSY



PRODUCT DESCRIPTION:

The Bi-Level Motion Sensor is a line voltage switching occupancy sensor with 0-10V output for dimmable ballast or LED driver control. This sensor will provide full power output for dimmable ballast or an LED module when it detects the presence of an occupant, or vehicle, and switch back to the low dim level after the area is vacated for a period of time. The motion sensor is available with various mounting options and interchangeable lenses. The sensor is designed to operate in the coldest of environments, down to -40°C/°F

FEATURES:

- Includes daylight harvesting for LUX level hold off at three different levels
- Capable of providing bi-level light control
- Omni-directional quad element infrared sensor
- 100~277VAC universal line voltage powered
- Frequency detection zero-cross relay switching
- 0-10V selectable output for low dim control
- Walk test and sensor operation LED indicator
- Direct lead wires for easy wiring connections
- 8 rotary DIP switch selectable control modes
- 7 low dim levels changeable via Accu-Set
- Available with variety of mounting options
- Available with interchangeable lens option

INSTALLATION NOTES:

1. The sensor is more sensitive to the movements “crossing” the detection zones than “toward” or “away” the sensor unit. To obtain better sensitivity, avoid placing the sensor in line with occupant path, if possible.
2. The closer the movement is to the sensor, the more sensitive the sensor is. The higher the sensor is installed, the larger movement is required to be detected.
3. Ensure to place the sensor at least at 1.5m (5 ft.) away from air supply ducts as rapid air flow may cause false activations.
4. The sensor cannot “see” the movements behind obstacles, such as furniture, shelf, glass or partition. As a general rule, each occupant should be able to clearly view the sensor unit.
5. For open office areas with partition which could block the sensor view to occupant movements, it is best to place the sensors over the intersection of multiple workstations. For large areas of open office or space, place multiple sensors so that there is overlap coverage with each adjacent sensor

SENSOR RANGE TESTING:

1. Set the control mode switch pointing to position “A”.
2. Walk within the desired range* at normal speed. Light should be switched ON for 5 seconds and dim for 10 seconds whenever sensor detects the movement.
3. The LED indicator behind the lens assembly will blink to indicate sensor detection as well.

ORDERING:

ORDER CODE	MODEL NUMBER	DESCRIPTION
73872	MSITXLOD500SPASSY	SENSOR MOTION 120-277V OCC DLH IP66 EXTERNAL HOUSING, STD 10.5 LEADS

*ALL ORDERED FIXTURES WILL COME WITH APPLICABLE PRODUCT LENS/ HOUSING INCLUDED. CONTACT MAXLITE IF VARIATION IS NEEDED.

SPECIFICATION:

SPECIFICATIONS	MSITXL0D500SPASSY
POWER SUPPLY	100/120/240/277VAC, 50/60Hz
MAX LOAD	800W (VA)
LOW DIM LEVEL	0/5/10/20/25/33/50% SELECTABLE
LOW DIM CONTROL	0-10V
INFRARED SENSOR	Omni-directional quad element pyroelectric
LOAD SWITCHING	ZERO-CROSS AUTOMATIC FREQUENCY SWITCHING
HIC PROTECTION	MAX. 80A FOR 16.7 msec.
DETECTABLE SPEED	0.5-10FT/SEC
MOUNTING HEIGHT	SUBJECT TO TO LENSE TYPE APPLIED
DETECTION RANGE	SUBJECT TO TO LENSE TYPE APPLIED AND HEIGHT
AMBIENT LIGHT LEVEL	L:20~50 lux, M:80~130 lux, H:500~600 lux
DELAY TIME SETTING	1'3'5'10'15'20'30' selectable
TIME-OFF DELAY	10 MIN, TO MODES ONLY
OP HUMIDITY	MAX 95% RH
OP TEMPERATURE	-40°F~158°F
DIMENSIONS	2.36"x H1.45"

WIRING DIAGRAM:

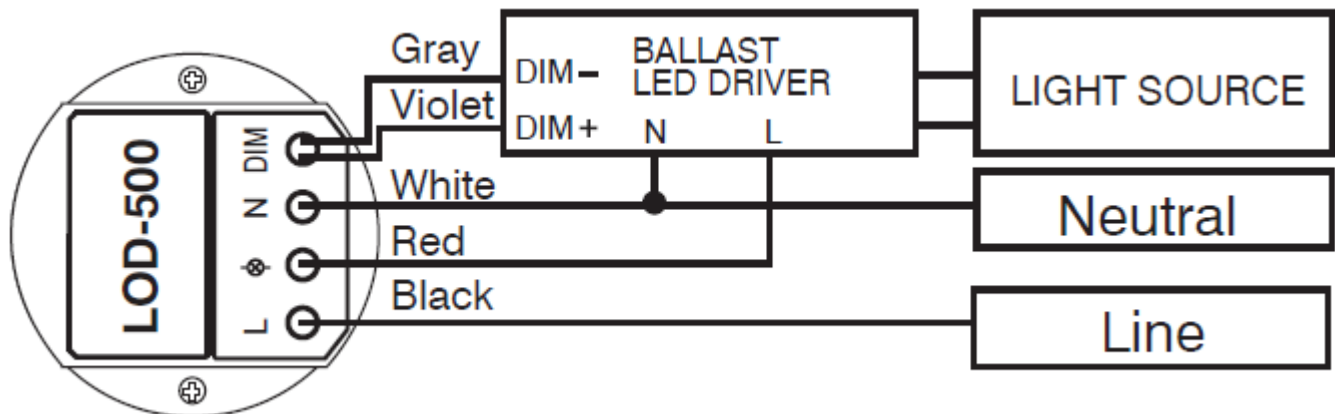

SENSOR CONTROL MODES:

The Bi-Level Motion Sensor features 8 different control modes selectable via rotary DIP switch. Please refer to the following description and select the desired control mode.

NOTE: Ensure to set the DIP switch at “click” position while setting the control mode.

Mode	Sensor Control Description
A	<ol style="list-style-type: none"> 1. Turn on the light for 5 seconds at every motion detected. 2. Dim the light for 10 seconds and then turn off.
B	<ol style="list-style-type: none"> 1. Ambient light sensor is disabled with this mode. 2. Dim the light to low level as DIM set all time under vacancy. 3. Turn the light to full-ON per delay TIME set under occupancy.
C	<ol style="list-style-type: none"> 1. Light off while ambient light is higher than 50 lux. 2. While ambient light is lower than 20 lux, dim the light to low level as DIM set under vacancy. 3. Turn the light to full-ON per delay TIME set under occupancy.
D	<ol style="list-style-type: none"> 1. Light off while ambient light is higher than 130 lux. 2. While ambient light is lower than 80 lux, dim the light to low level as DIM set under vacancy. 3. Turn the light to full-ON per delay TIME set under occupancy.
E	<ol style="list-style-type: none"> 1. Light off while ambient light is higher than 600 lux. 2. While ambient light is lower than 500 lux, dim the light to low level as DIM set under vacancy. 3. Turn the light to full-ON per delay TIME set under occupancy.
F	<ol style="list-style-type: none"> 1. Light off while ambient light is higher than 50 lux. 2. While ambient light is lower than 20 lux, light stays off under vacancy. 3. Turn the light to full-ON per delay TIME set under occupancy. When delay time elapse, dim the light to low level as DIM set for 10 minutes as Time Off delay. 4. Turn the light to full-ON per delay TIME set if sensor detects occupancy during Time Off. Turn the light off if no occupancy detected during Time Off delay.
G	<ol style="list-style-type: none"> 1. Light off while ambient light is higher than 130 lux. 2. While ambient light is lower than 80 lux, light stays off under vacancy. 3. Turn the light to full-ON per delay TIME set under occupancy. When delay time elapse, dim the light to low level as DIM set for 10 minutes as Time Off delay. 4. Turn the light to full-ON per delay TIME set if sensor detects occupancy during Time Off. Turn the light off if no occupancy detected during Time Off delay.
H	<ol style="list-style-type: none"> 1. Light off while ambient light is higher than 600 lux. 2. While ambient light is lower than 500 lux, light stays off under vacancy. 3. Turn the light to full-ON per delay TIME set under occupancy. When delay time elapse, dim the light to low level as DIM set for 10 minutes as Time Off delay. 4. Turn the light to full-ON per delay TIME set if sensor detects occupancy during Time Off. Turn the light off if no occupancy detected during Time Off delay.

Mode Operation Chart

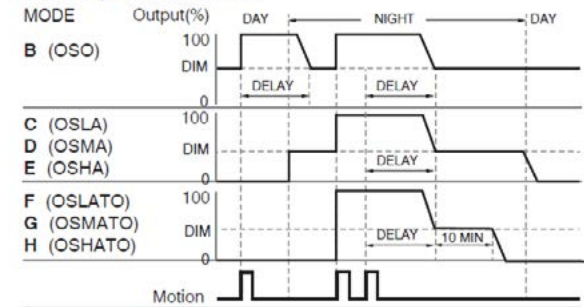

SENSOR SETTINGS:

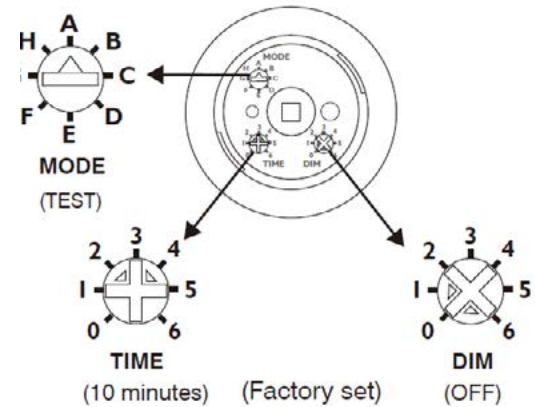

POS.	0	1	2	3	4	5	6
TIME	1'	3'	5'	10'	15'	20'	30'
DIM	OFF	5%	10%	20%	25%	33%	50%