

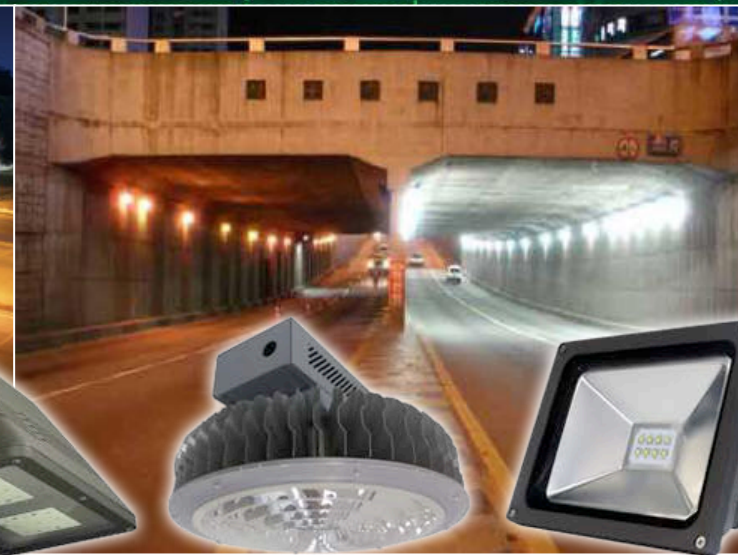

WELCOME

S/P RATIO & DELIVERED LUMENS VS. TOTAL LUMENS



PART 1

Scotopic/Photopic Ratio

- The issue:
Human perception of the lighted environment is driven by both **Photopic and Scotopic** vision.

... but ...

Only Photopic vision is typically considered applicable to light metering.

How do we measure light now?

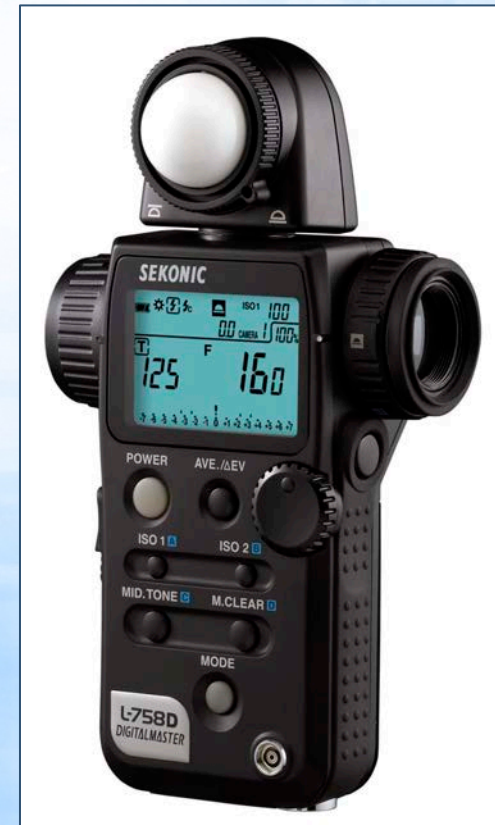

Photopic:

- Known as light or daylight vision (“cones”)
- Higher sensitivity in “brighter” light
- Peak sensitivity towards “red” (550 nm)
- Basis for modern photometry (light metering)

Scotopic:

- Known as dark or night vision (“rods”)
- Higher sensitivity and speed in different spectral range
- Peak sensitivity towards “blue” (500 nm)
- High color temperature lamps 5000K - 7000K

- **Rods are active in bright light and do contribute to the perception of brightness.**
- **Scotopic contributes to improved acuity but this is not yet well defined.**
- **Higher Scotopic sources can provide equivalent brightness with lower energy.**

Now let's discuss S/P Ratio...

Combination of Scotopic & Photopic

- There is usually complexity, if not trouble, whenever we mix physics with biology.
- The physical side of things - the radiant power of a light source – is simply enough defined and is well-behaved.
- The biological side of things - the evoking of a visual sensation - is very hard to define and not at all well-behaved.





Scotopic/Photopic Ratios

Light Source	Scotopic / Photopic Ratio (S/P)
High Pressure Sodium (35W)	0.40
Low Pressure Sodium	0.20
Warm White Fluorescent	1.00
Cool White Fluorescent	1.46
Metal Halide (Sodium/Scandium)	1.49
Quartz Halogen (~3200° K)	1.50
4100°K LED/Fluorescent	1.54
5000°K LED/Fluorescent	1.96
6500°K LED/Fluorescent	2.14

WHITE LIGHT



3000k - 52 CRI



3000k - 82 CRI

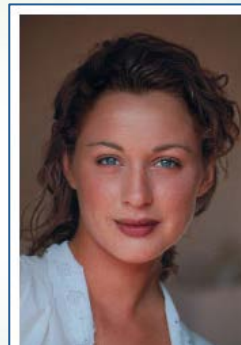

6500k - 82 CRI

How it can affect your business



**250W
HPS**

$$= 24,500 \times 0.62 = 15,190$$

Photopic Lumens **S/P Ratio** **Scotopic Lumens**



**140W 5000K
MaxLite LED
Area Light**

$$= 8,400 \times 1.96 = 16,464$$

Photopic Lumens **S/P Ratio** **Scotopic Lumens**

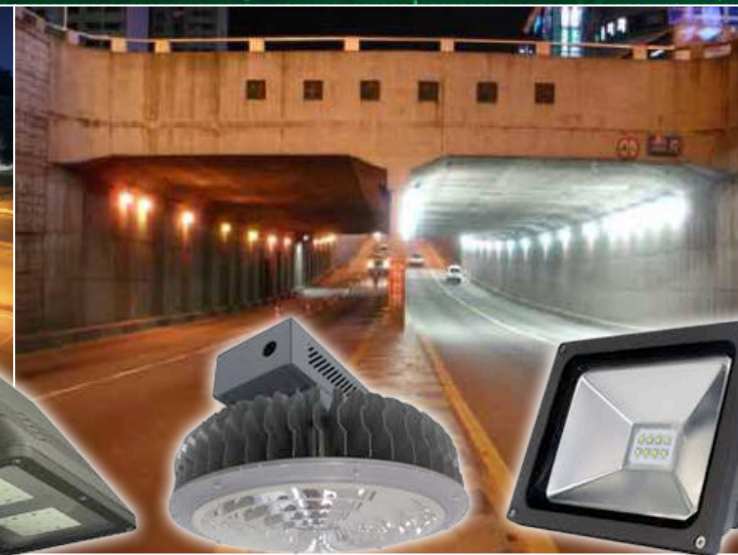

PART 2

DELIVERED LUMENS VS. TOTAL LUMENS

Total Lumens:

- Omni-directional light sources require 78% of the output to be redirected.

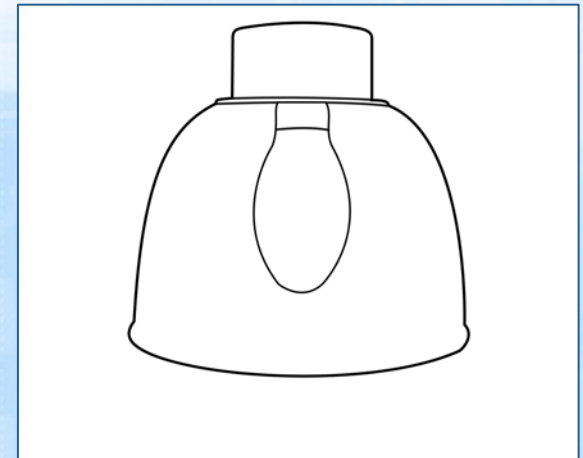
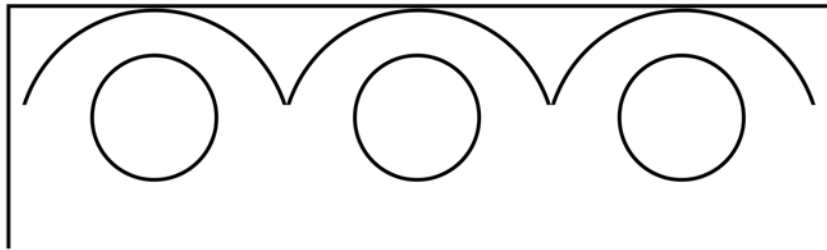

Total Lumens:

- Omni-directional light sources require 78% of the output to be redirected.
- Majority of the reflections are directed back into the bulb. (light source)

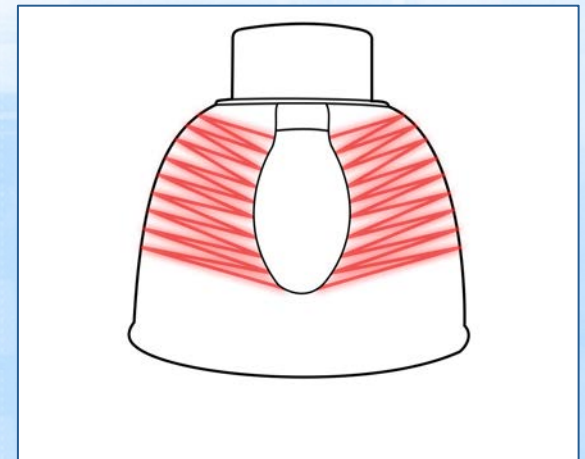
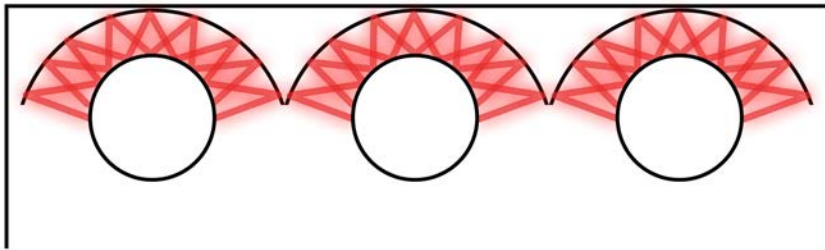

Total Lumens:

- Omni-directional light sources require 78% of the output to be redirected.
- Majority of the reflections are directed back into the bulb. (light source)
- Energy is lost and compounded with every reflection.

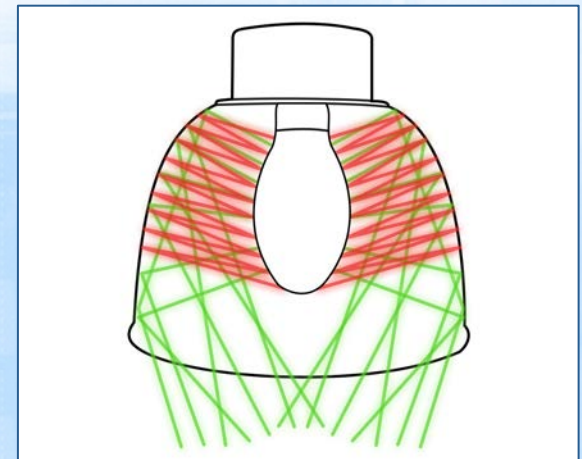
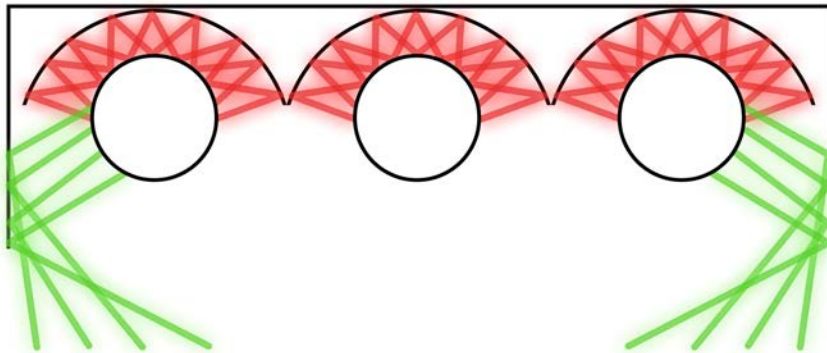

Total Lumens:

- Omni-directional light sources require 78% of the output to be redirected.
- Majority of the reflections are directed back into the bulb. (light source)
- Energy is lost and compounded with every reflection.
- Most light traces require multiple reflections before hitting the work surface.

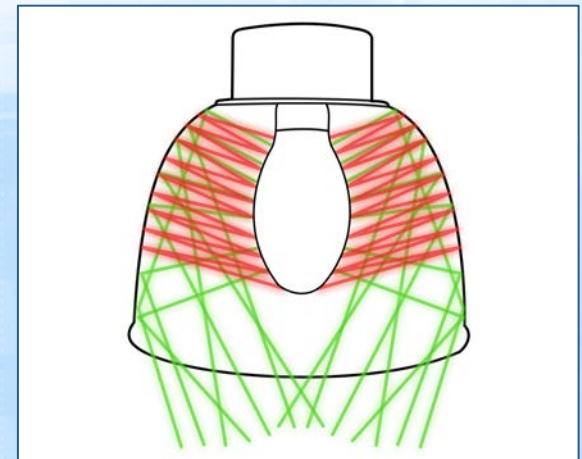
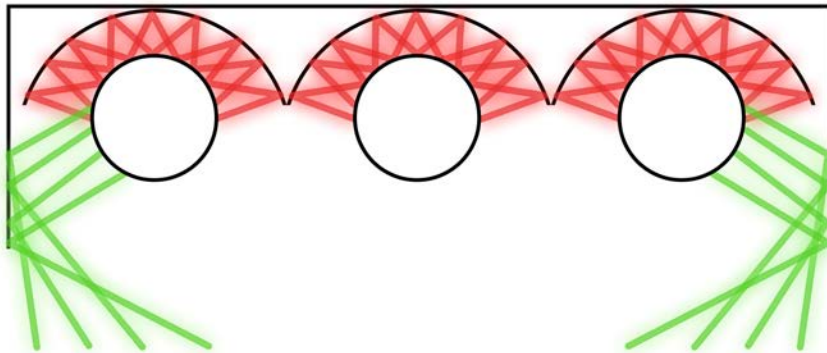

Total Lumens:

- Omni-directional light sources require 78% of the output to be redirected.
- Majority of the reflections are directed back into the bulb. (light source)
- Energy is lost and compounded with every reflection.
- Most light traces require multiple reflections before hitting the work surface.
- Less than 14% of the source lumens trace directly to the work surface.

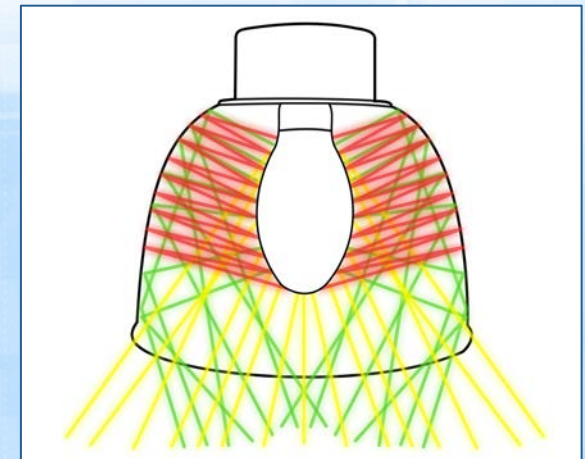
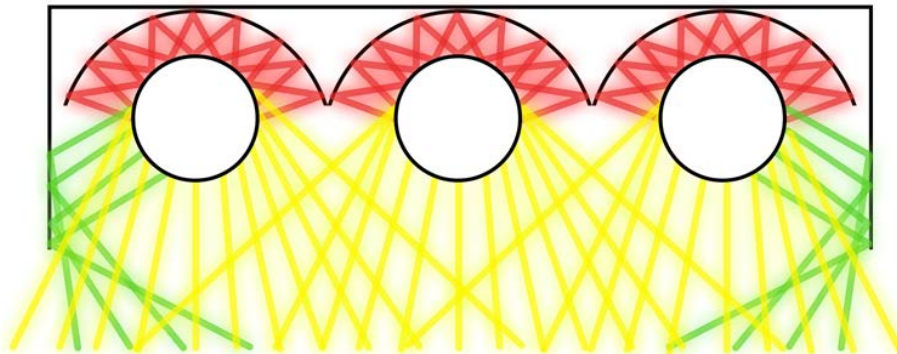

Delivered Lumens:

- More than 94% of (mono) directional lumens are delivered.

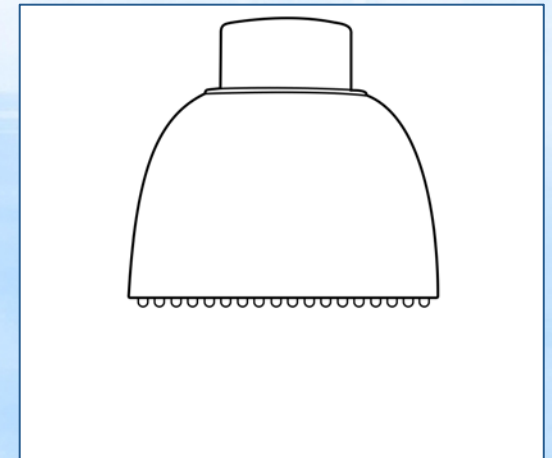
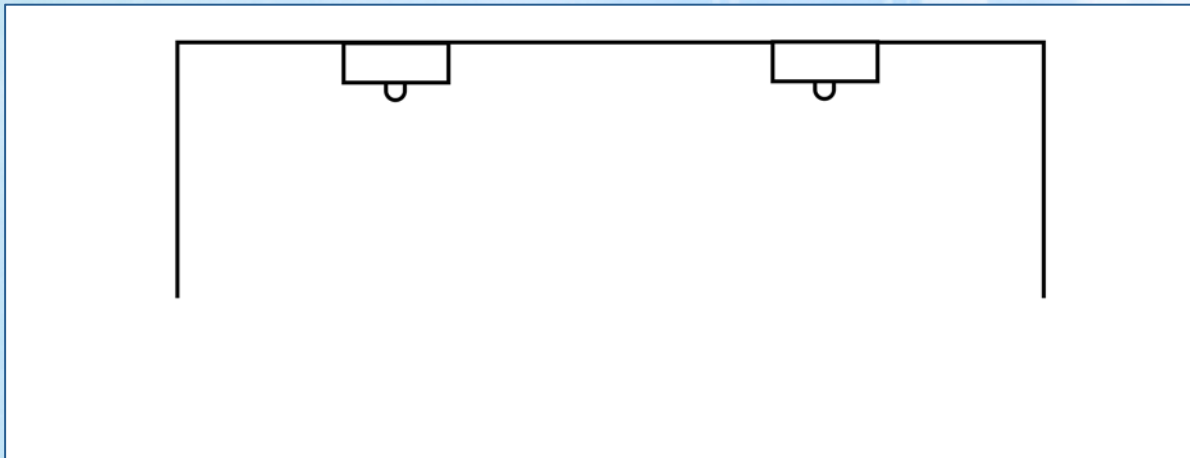

Delivered Lumens:

- More than 94% of (mono) directional lumens are delivered.
- 80% of total lumen output is delivered directly to the work surface.

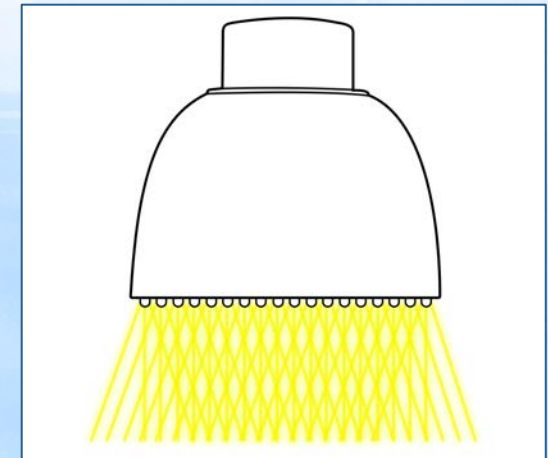
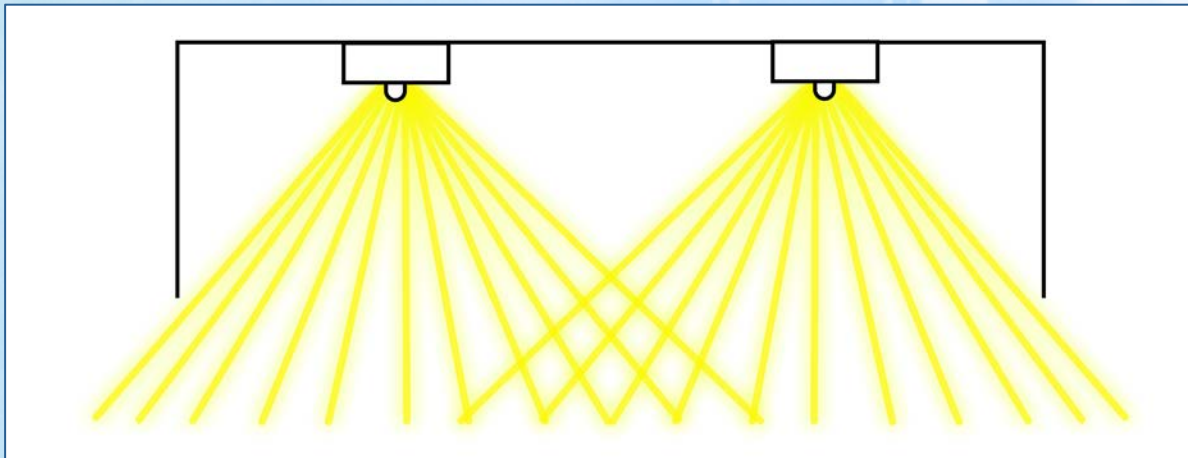

Delivered Lumens:

- More than 94% of (mono) directional lumens are delivered.
- 80% of total lumen output is delivered directly to the work surface.
- The remaining 20% are reflected only once to the target.

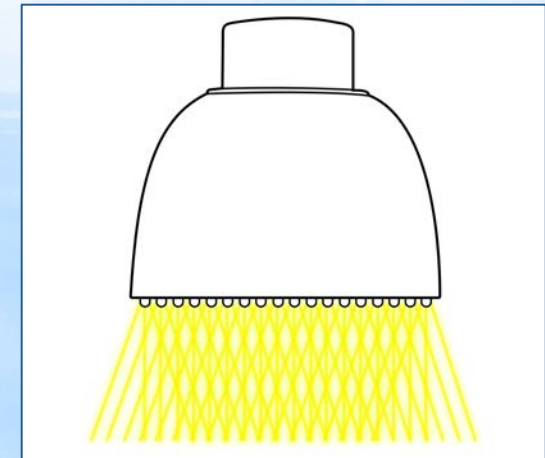
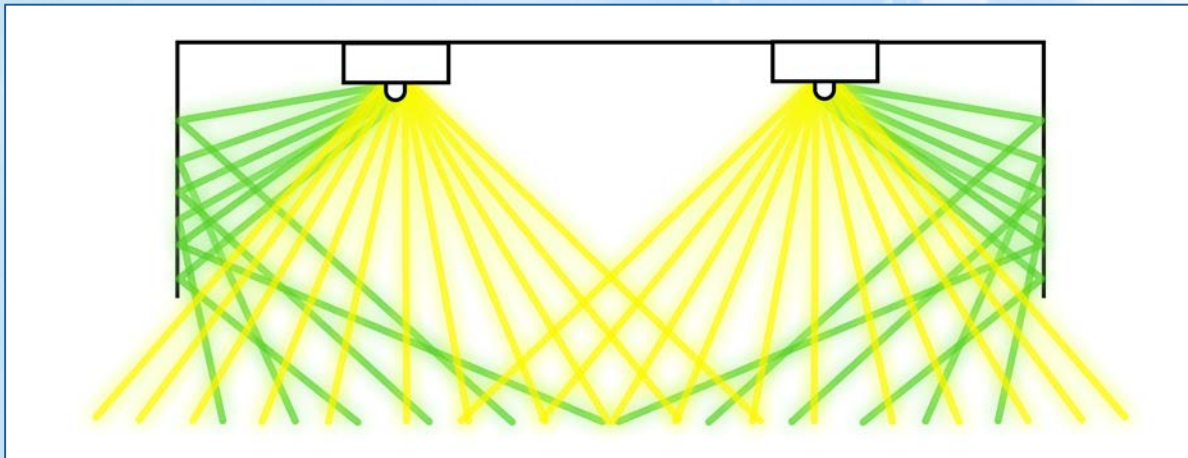

Delivered Lumens:

- More than 94% of (mono) directional lumens are delivered.
- 80% of total lumen output is delivered directly to the work surface.
- The remaining 20% are reflected only once to the target.
- None of the lumens are reflected back into the bulb. (light source)

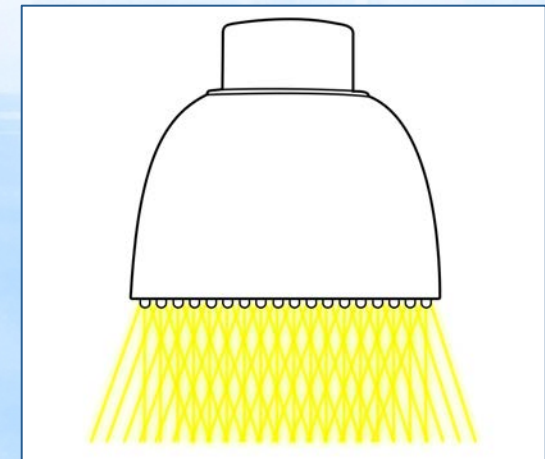
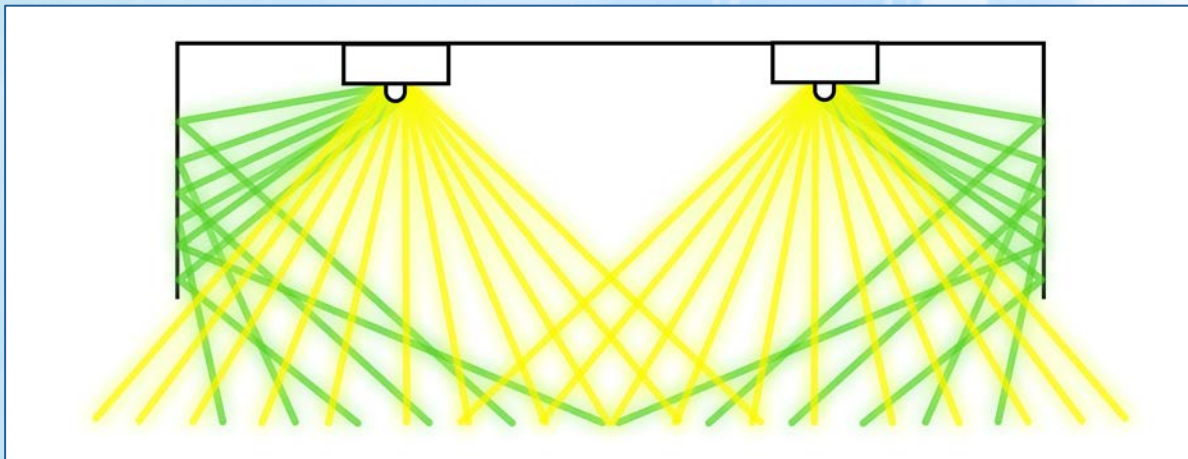

Delivered Lumens VS. Total Lumens

Total Lumens:

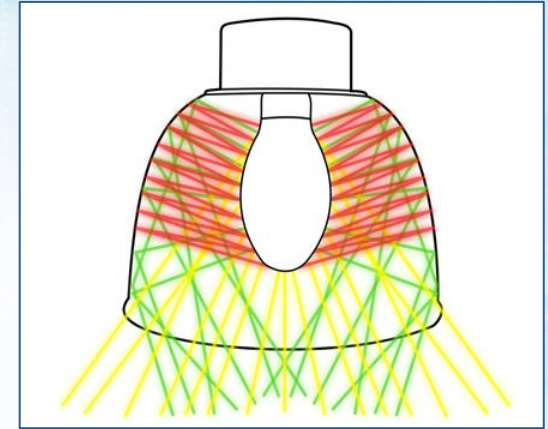
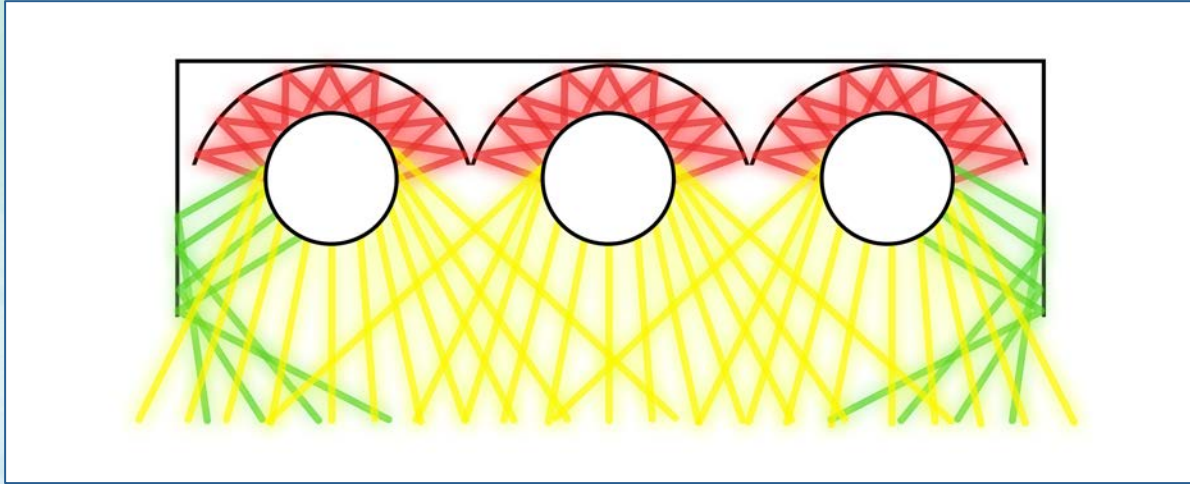

Delivered Lumens:

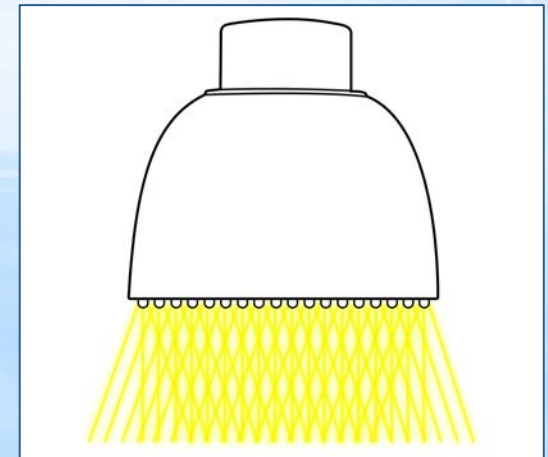
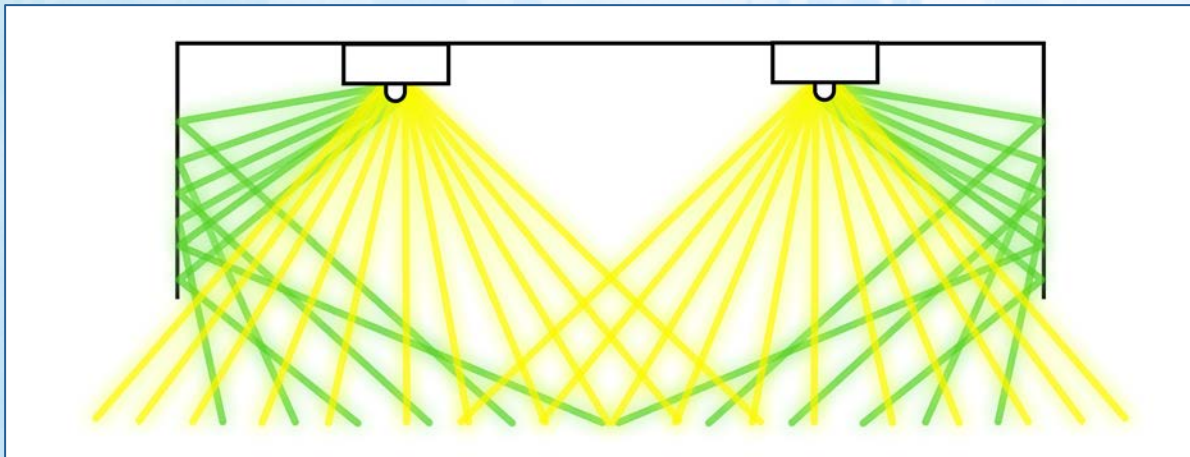

Foot-Candles

Instead of lumen output, the best and most relevant measurement for evaluating LED light fixtures and for making accurate comparisons with conventional light fixtures is **Delivered Light**. The formal term for measurements of delivered light is illuminance. Roughly speaking, illuminance is the intensity of light falling on a surface area. If the area is measured in square feet, the unit of illuminance is **Foot-Candles**. If measured in square meters, the unit of illuminance is lux.

Plan View
Scale 1" = 8'

DATA CENTER
10' x 8' SPACING

DISCLAIMER: This calculation is based on the best information provided to MaxLite by the client. These findings should be verified by a certified electrical engineer as to their accuracy. Design changes such as wall, ceiling, floor heights and reflectances of all interior surfaces including partition walls may adversely affect the overall light levels. MaxLite is not responsible as to the veracity of these calculations, and should only be used as a design reference tool.

Calculated values include direct and interreflected components.

LUMINAIRE SCHEDULE									
Symbol	Label	Qty	Catalog Number	Description	Lamp	File	Lumens	LLF	Watts
	A	48	MLCP22D4050 AFF.	WITH WHITE INTERIOR AND FROSTED PLASTIC FLAT LENS	240 LEDS, LUMINAIRE OUTPUT = 3649 LMS	MLCP22D4050 .IES	Absolute	0.95	37

STATISTICS					
Description	Symbol	Avg	Max	Min	Max/Min
2.5' AFF		45.7 fc	52.9 fc	33.7 fc	1.6:1

Client

Date: Sep 10 2012

CalcBy: D DELGADO

File No: DATA.1 091012

1 of 1

Delivered light aka **Delivered Lumens** describes how much useful light a light fixture can deliver to a task area discounting any wasted light. Light can be wasted in a number of ways: It can be partially blocked or dispersed within the fixture housing, it can be emitted in a direction away from the task area, or it can be lost through filtering, lensing, fixture positioning, or any of a number of other factors relevant to a specific installation.

A fixture's total lumen output does not account for wasted light. Because LED lighting fixtures are fundamentally directional, LED fixtures typically waste much less light than their conventional counterparts, and deliver more of their total light output to a task or target area. An LED light fixture with lower rated lumens, therefore, may deliver the same or more useful light in a specific application than a comparable conventional lighting fixture with a higher rated lumen output.

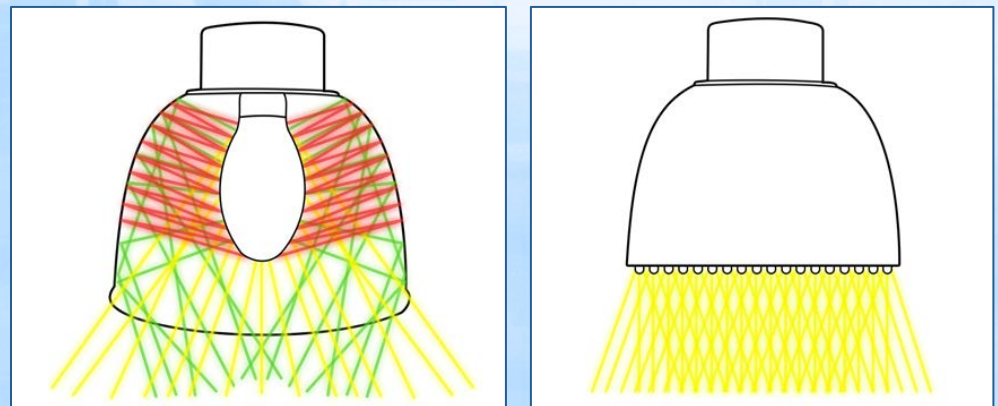

In evaluating light fixtures, you have to compare the reported light output of LED lighting fixtures with the reported light output of conventional light sources. To make accurate comparisons, you need to understand the differences in the methods for gathering and reporting photometric data for conventional and LED lighting fixtures.

FYI:

Conventional lighting fixtures are tested using the relative photometry method. In relative photometry, luminaires and the lamps used within them are tested separately. Lamp and luminaire testing differ so much from one another, in fact, that lamp photometry engineering and luminaire photometry engineering are separate specialties, each with its own standards and practices. The total luminous flux and chromaticity (color) of a fixture's lamps are typically measured with integrating spheres, while the luminous intensity distribution and efficiency of the luminaires are usually measured with goniophotometers.



Traditional Fixtures

Conventional lighting fixtures are tested using the relative photometry method. In relative photometry, luminaires and the lamps used within them are tested separately. Lamp and luminaire testing differ so much from one another, in fact, that lamp photometry engineering and luminaire photometry engineering are separate specialties, each with its own standards and practices. The total luminous flux and chromaticity (color) of a fixture's lamps are typically measured with integrating spheres, while the luminous intensity distribution and efficiency of the luminaires are usually measured with goniophotometers.



LED Fixtures

Because LEDs are typically inseparable from the luminaires in which they act as light sources, relative photometry is inappropriate for measuring the light output of LED fixtures. Instead, LED fixtures are tested using absolute photometry. The approved procedures and testing conditions for absolute photometry are spelled out in *Electrical and Photometric Measurements of Solid-State Lighting Products*, publication **IES LM-79-08**, published by IESNA in early 2008.

In absolute photometry, only fixture lumens are measured, and not lamp lumens, because a separate measurement of the LEDs independent of the fixture is neither possible nor meaningful. Fixture efficiency, which compares lamp lumens to fixture lumens, therefore has no meaning for an LED lighting fixture.

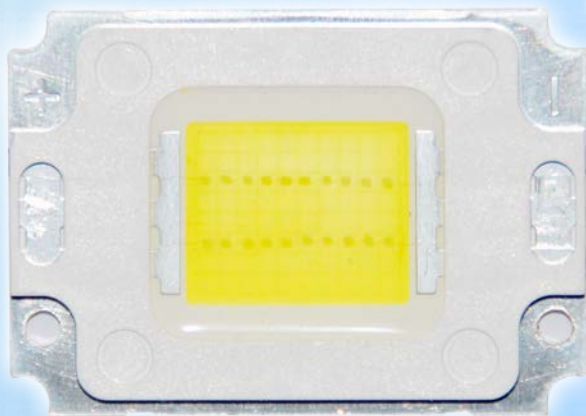

Specifiers, designers and distributors need to compare the total lamp lumens of a conventional lighting fixture with the total fixture lumens of an LED fixture. To make a valid comparison, you must reduce the measured lamp lumens of the conventional fixture by its efficiency. This reduction is typically reported in a Zonal Lumen Summary chart.

For example, the T2 under-cabinet fluorescent light fixtures, prominently reports 860 lumens for the two T2 lamps used within the fixture.

However, the Zonal Lumen Summary chart reports 575 total fixture lumens, because the fixture outputs only 66.9% of the total lamp lumens (66.9% of 860 = 575).

That means that 33.1% of the light produced by the fixture's lamps is wasted or lost within the fixture housing.

When comparing a T2 under-cabinet fixture to an LED-based under-cabinet fixture designed for similar lighting applications, you should compare the LED-based fixture's total lumens with the efficiency-corrected lumen total of the T2, not with its reported lamp lumens. The best way however is to have a lighting layout showing before and after fc's.

ZONAL LUMEN SUMMARY

Zone	Lumen	% Lamp	% Fixt.
0-30	113	12.1	19.6
0-40	199	23.1	34.6
0-60	382	44.4	66.3
0-90	534	62.1	92.8
90-120	38	4.4	92.8
90-130	40	4.7	7.0
90-150	41	4.8	7.2
90-180	41	4.8	7.2
0-180	575	66.9	100.0

The total fixture lumens of a conventional lighting fixture, which accounts for fixture efficiency, should be used in comparisons with the lumen output of LED fixtures.

MaxLite Webinars

MaxLite has been hosting free webinars once per month on a variety of topics since 2010. A lot of great content has been presented, here's how to find it:

- To browse previous MaxLite Webinars, visit: <http://www.maxlite.com/webinar>
- Check/Subscribe to our YouTube channel



Class Is In Session! 24/7

- Visit the MaxLite Lighting & Technology University at: <http://university.maxlite.com> to learn about all of MaxLite's products and gain access to many other lighting resources!



QUESTIONS & ANSWERS:

Thank you everyone for your attention.

This webinar session will be left open for the next 10 minutes to allow time for questions. We will answer as many questions as we have time for right now, but ALL questions will be answered via e-mail within the next 24 hours.

Thanks again for attending, and we hope to speak to you again, soon!

FOR MORE INFORMATION ABOUT OTHER MAXLITE PRODUCTS; OR FOR LIGHTING QUESTIONS IN GENERAL; PLEASE CONTACT:

info@maxlite.com

www.maxlite.com

1-800-555-5629

Or contact your MaxLite Representative or MaxLite's Regional Sales Manager.