

# COMMERCIAL FIXTURES AND LAMPS SPECIFICATIONS

## 2x2 & 2x4 Architect LED Flat Panels

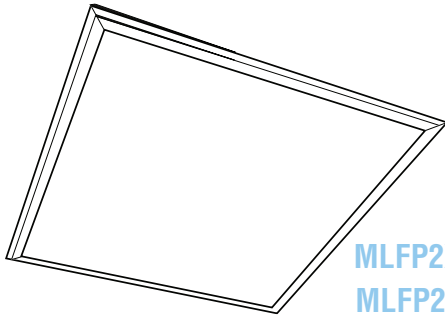

MLFP2X235  
MLFP2X250

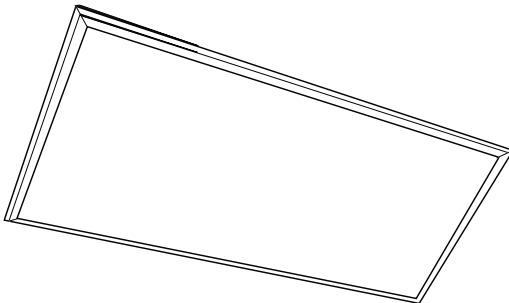

MLFP2X435  
MLFP2X450



For more information on MaxLite products, visit:  
[www.MaxLite.com](http://www.MaxLite.com). Click on "PRODUCT LINE"

### FOR ORDERING:

Tel: 1-800-555-5629  
Fax: 973-244-7333  
E-mail: [info@maxlite.com](mailto:info@maxlite.com)

MaxLite  
12 York Ave  
West Caldwell, NJ  
07006

### PRODUCT FEATURES:

- Remote Control / Fully dimmable
- 50,000 Hour Life – Based on 30% lumen depreciation
- Self Driven – No additional drivers required
- Unique mounting gives flush fit in drop ceilings
- Slim profile enables installation in low depth cavities
- Mercury Free
- Available with 3rd Party Graphic Elements – Consult Factory for details

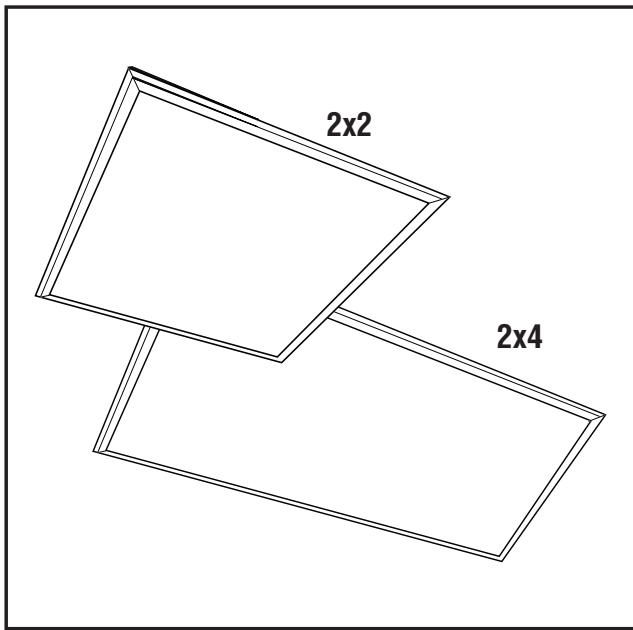

# MAXLITE™ 2x2 & 2x4 Architect LED Flat Panels

**Construction:** : A high performance LED flat panel designed for installation in drop ceilings; typically used to replace standard 2x2 and 2x4 fluorescent fixtures. The profile is slim, only 3 inches deep including the junction box, so the fixture is ideal for low depth ceiling cavities.

The housing and the back panel are aluminum to provide maximum heat sink and thermo control capabilities. The trim also acts as a heat sink, and in keeping with the high quality of the rest of the materials the lens is a translucent white polycarbonate.

Because of the quality and solidity of the materials, the fixtures have weight; the 2x4 is 35 lbs and the 2x2 is 14 lbs. (Earth quake safety tabs included).

Both panels are fully dimmable with a smooth 12 level remote dimmer, and both are wired for smart controls (See Controls on following sheet.)

## PRODUCT FEATURES:

- Remote Control / Fully dimmable
- 50,000 Hour Life – Based on 30% lumen depreciation
- Self Driven – No additional drivers required
- Unique mounting gives flush fit in drop ceilings
- Slim profile enables installation in low depth cavities
- Control whole room with one Master
- Control whole building with one control
- Mercury Free
- Available with 3rd Party Graphic Elements – Consult Factory for details

A Special Order version of the LED Flat Panels can be purchased for Hospital and Health Facility MRI rooms. These panels are manufactured from materials which are completely non-interfering:

## HOSPITAL/MRI ROOM PRODUCT FEATURES:

- A remote driver up to 30' distance
- All non-ferrous metals
- Surface-mount options
- Stainless steel fasteners
- Low temperature operation
- Optimized germ-free wipe down.

Any of the existing or special-order models can be manufactured in the MRI Version.



Commercial



Hospitals



# 2x2 & 2x4 Architect LED Flat Panel Controls

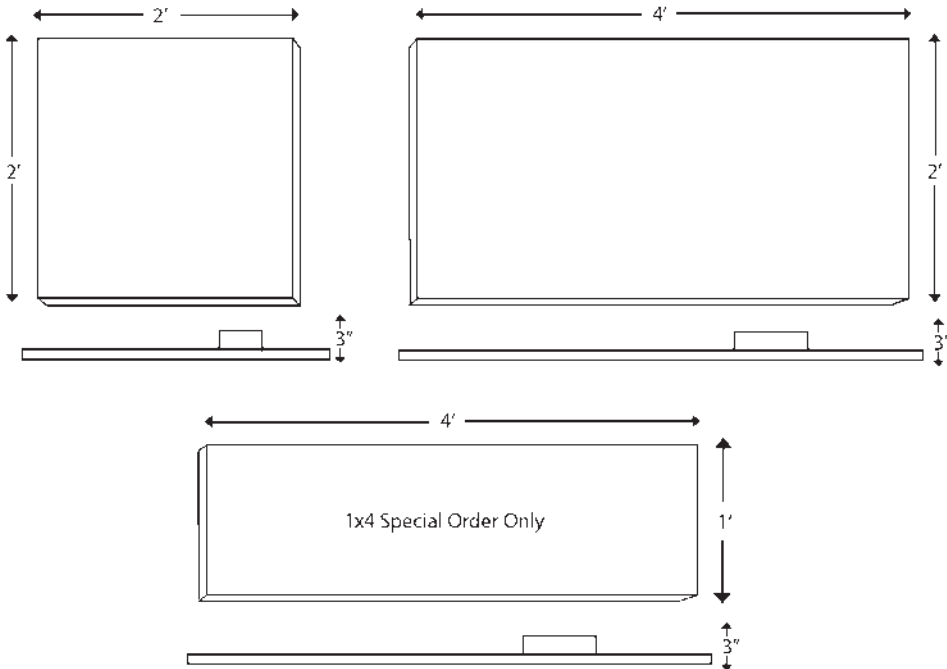
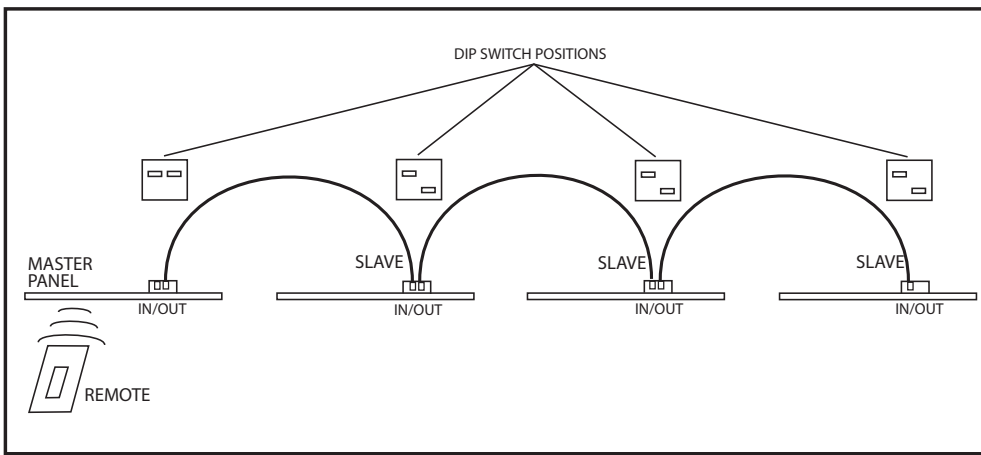

**MASTER/SLAVE:** Each panel (both 2x2 and 2x4) has a Master/Slave switch on the back. During mounting, one fixture in the room should be switched to Master, and the others in the room should be switched to Slave. With supplied regular RJ25 cord (telephone cords with telephone jacks) each fixture is joined to the next (see diagram left)

**ROOM CONTROL:** When all the units are joined, one remote control aimed at the Master Unit will control all the other units in the room, up to a maximum of 10 units. With one click, all the units can be turned on, dimmed and turned off. The Master Unit controls the whole room, up to 10 fixtures.

**BUILDING CONTROL:** Multiple panels can also be controlled from a single source. The panels can be linked to a DMX512 controller.

For information and specifications on either linking more than 10 panels, or on Green Building DMX controls please contact MaxLite.

## SPECIFICATIONS:

### Watts:

2x4 Typical 93W / Max 105 W

2x2 Typical 54W / Max 61W

### Illumination: (at one meter)

2x2 Typical 1200 LUX / Max 1500 LUX

2x4 Typical 1500 LUX / Max 1700 LUX

## SPECIFICATIONS:

- CRI 70
- Operating Temp: 14°F to 104°F
- Input Power: AC 120-277V, 50-60 Hz
- Power Factor: (At Max Load) 90% HPF.
- Controls - IR Remote: 0 to 10 dimming, on/off  
Master/Slave: RJ25 Control  
DMX: DMX512 Control

## LED FLAT PANEL SPECIFICATIONS

\* Photometrics & IES files available at [www.maxlite.com](http://www.maxlite.com)

Order Code	Model Number	Description	Wattage	CRI	Weight (lbs)	LEDs	Lumens	Life (Hrs)	K
70476	MLFP2X235	LED Flat Panel 2' x 2'	60	70	14	234	3150	50,000	3500
70477	MLFP2X250	LED Flat Panel 2' x 2'	60	70	14	234	3150	50,000	5000
70478	MLFP2X435	LED Flat Panel 2' x 4'	90	70	35	468	5000	50,000	3500
70479	MLFP2X450	LED Flat Panel 2' x 4'	90	70	35	468	5000	50,000	5000
SPECIAL ORDER ONLY		LED Flat Panel 1' x 4'	60	70	14	234	3150	50,000	3500
SPECIAL ORDER ONLY		LED Flat Panel 1' x 4'	60	70	14	234	3150	50,000	5000

